

**Torque  
Limiting  
Overload  
Protection  
UEP Modular  
Torque  
Protection**



**BIBBY TURBOFLEX™**

A REGAL REXNORD BRAND

## UEP MODULAR TORQUE LIMITERS

Bibby Turboflex has through extensive experience developed the Ultimate Extruder Protection device affording reliable protection for twin screw extruders.

Based on over 30 years experience in arduous applications particularly in the steel industry has led to the development of the Bibby Modular Torque Limiter which has become the industry standard for twin screw extruder machines.

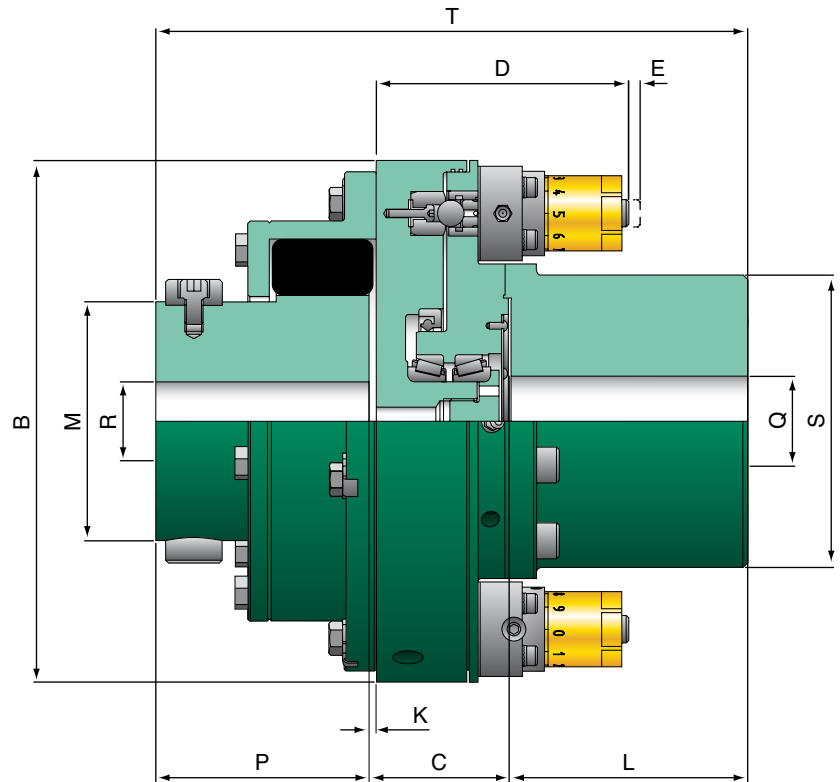

### UEP Ratings and Dimensions

Model Number	234A	237A	238A	238B	239B	300C
Maximum Preset Torque Nm	1480	3046	3577	6688	8786	14280
Minimum Preset Torque Nm	148	493	579	1122	1420	2310
Maximum Speed RPM	3000	2800	2800	2500	2500	2200
Coupling Size	0.2RB	0.37RB	0.73RB	0.73RB	1.15RB	2.15RB
Module Size	SE5	SE10	SE10	SE10	SE10	SE10
Quantity of Modules	2	2	2	4	4	6
Dimensions (mm)						
Outside Diameter - B	232	278	317	320	378	467
Distance Between Hub Faces - C	62.3	83.5	83.5	96.7	96.7	110.7
D	112	134	133	138	138	136
E	3	4	4	4	4	4
Overall Length - T	264	325	350	363	407	441
Rigid Hub						
Boss Diameter - S	130	165	165	190	234	234
Hub Length - L	106	121	121	121	140	140
Maximum Bore - Q	90	115	115	135	165	165
Minimum Bore	32	40	40	50	55	55
Flex Coupling						
Gap - K	3.2	3.2	3.2	3.2	3.2	4.8
Boss Diameter - M	106.4	128.6	152.4	152.4	179.4	219
Hub Length - P	95	120	145	145	170	190
Maximum Bore - R	70	85	95	95	115	140
Minimum Bore	35	40	55	55	55	70
Mass Kg	39	70	90	106	163	231

Front cover photo courtesy of Coperion GmbH

## Features & Benefits

- **Accurate release torque repeatability**
- **Simple fast manual re-engagement**
- **Low-cost maintenance**
- **The preferred protection for many extruder manufacturer**

Very accurate release torque repeatability with minimal variation between static and dynamic release. Versatile installation allows for the torque limiter center section to be removed without the need to move the motor or gearbox.

Individual modules are preset to provide the required release torque. Any maintenance of the modules is a straightforward operation. A simple removal operation allows for module recalibration without having to replace the complete unit. By holding spare modules in stock already preset to the required release torque keeps downtime to an absolute minimum.

Manual reset of the torque limiter can only be carried out when the drive is at rest. Resetting is achieved by realigning the two halves of the unit and then lightly tapping each module fitted, with a soft mallet.

Lubrication of the unit is via easy access grease nipples. Proximity sensor targets are included to provide the means to switch off the drive after an overload occurs.

While each torque limiter assembly is normally factory preset, if required site adjustments can be carried out, a setting chart with instructions is provided for this purpose. Please note a security key is required and adjustment should only be carried out by an authorized person.

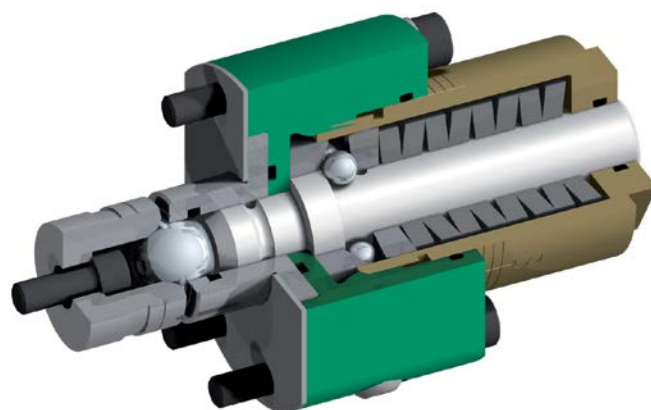

## Normal Operation

The flange connection is driven by a large steel ball (2), located in the detent pocket (1), which is retained by a plunger (3). This in turn is retained axially by means of a system of angled races (5,7) biased by pressure from the Belleville springs (4), acting on a circle of balls (6).

## Disengagement

On overload, relative angular movement between the flanges imparts a tangential force ( $F_u$ ) on the large steel ball, forcing it clear of the detent pocket back against the plunger. This in turn causes the plunger to be forced through the circle of balls overcoming the spring loading on the angle races. In this position, the balls are resting on the large diameter of the plunger, and once this condition is reached the flanges are completely free to rotate independently. A suitable switch can be incorporated in the assembly to switch off the drive motor or operate a warning device when the Torque Limiting assembly disengages.

After first ensuring that the drive is isolated, resetting is a simple matter of first realigning the flanges and then tapping each module plunger back with a soft mallet to allow the circle of balls to return to their original position and the large steel ball to return to its location in the detent pocket.

**UEP Torque Limiters are not classed as machines by the 98/37/EU Directive and 2006/42/EU Machinery Directive. All installations must conform to industry standards.**

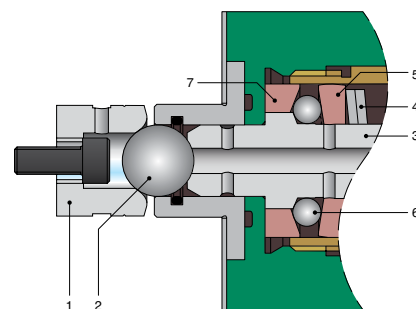

Engaged

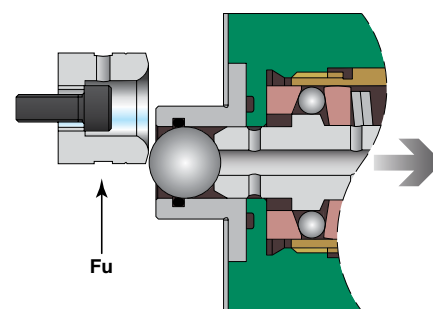

Disengaged

## Bibby Turboflex Facilities

### Europe

**United Kingdom**  
Bibby Turboflex, Unit 16  
Victoria Spring Business Park  
Wormald St, Liversedge  
WF15 6RA - England.  
+44(0) 1924 460801

*Disc, Gear, Grid Couplings,  
Overload Clutches*

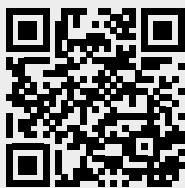

**Scan to see all  
the brands of  
Regal Rexnord**

Neither the accuracy nor completeness of the information contained in this publication is guaranteed by the company and may be subject to change in its sole discretion. The operating and performance characteristics of these products may vary depending on the application, installation, operating conditions and environmental factors. The company's terms and conditions of sale can be viewed at <http://www.altramotion.com/terms-and-conditions/sales-terms-and-conditions>. These terms and conditions apply to any person who may buy, acquire or use a product referred to herein, including any person who buys from a licensed distributor of these branded products.

©2023 by Bibby Turboflex LLC. All rights reserved. All trademarks in this publication are the sole and exclusive property of Bibby Turboflex LLC or one of its affiliated companies.